

REV.	DESCRIPTION	DATE	BY
1	Issue Drawing	11/6/2015	TR
2	Change part name & mold number.	3/16/2016	DJL

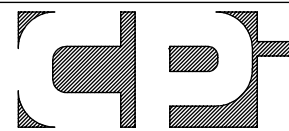
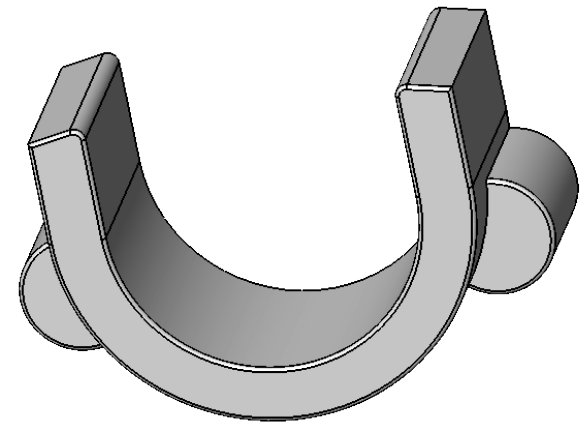
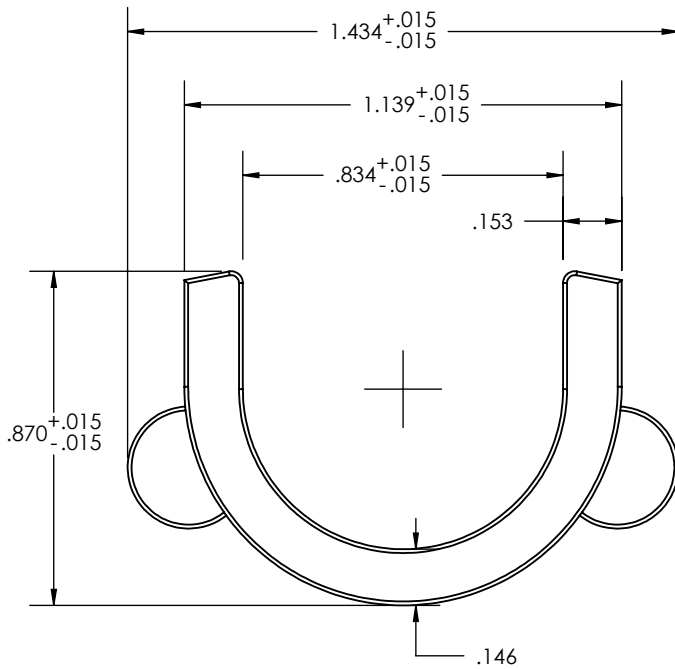
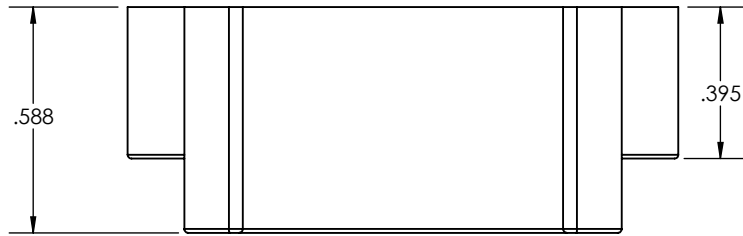

CAVALLERO PLASTICS INC.
 1250 NORTH ST. PHONE 413-443-0925
 PITTSFIELD MA 01201 FAX 413-443-9586
 E-mail sales@cplas.com

TOLERANCE UNLESS SPECIFIED OTHERWISE INCHES				ANGLES	PART NAME:	
.XXXX	.XXX	.XX	.X & FRAC.		± 1°	H G HER - GEAR BUSHING
MILLIMETERS				MOLD # 533, I-14		JOB # 85300
	± .130	± .40	± 3.0	SIZE A		DWG #
MAT'L: I.B.D.				DRAWING BY:		APPROVED BY:
DATE: 3/11/2015				DATE:		SCALE: 4:1
				SHEET 1 OF 1		REV 2